

# Thermographic signal processing through correlation operators in pulsed thermography

Matthieu T. Klein, Clemente Ibarra-Castanedo, Abdelhakim Bendada, Xavier P. Maldague\*  
Université Laval, Pav. Pouliot, Dpt. Gel-Gif, Local 1300, Québec, QC, Canada, G1K 7P4  
\*xavier.maldague@gel.ulaval.ca; phone 1 418 656-2962; fax 1 418 656-3159; mivim.gel.ulaval.ca

## ABSTRACT

In non-destructive testing by Infrared Thermography it is usually needed to locate defects and region of interests suspected to contain defects. The defects cannot always be observed directly from one single IR image taken at a single given time  $t$ . Thus, in the case of pulsed thermography, direct course techniques as the Fourier transform process the information of many images recorded for a given duration into one resulting image. Another way to compile the temporal information of a sequence of images into a single one is to compute a correlation image. This paper details an approach to use a statistical correlation operator to help improving defect detection in pulsed infrared thermography.

**Keywords:** Correlation image, infrared images, camera, non destructive testing, IR NDT, contrast, FFT, pulsed phase thermography, image enhancement, signal processing

## 1. INTRODUCTION

In active non-destructive testing by IR thermography, the sample to test is usually excited with an external source of heat. The source is either modulated in the case of lock-in thermography, or instantaneous in the case of pulsed thermography (PT). In both cases the transient state of heat diffusion is recorded as a sequence of  $N$  infrared images for duration of a time  $t$ . The biggest defects are obvious and immediately noticeable from single raw IR images. To detect smaller defects within the sample, efficient enhancement methods of the signature of the heat diffusion over the inspected specimen are needed [4]. Most of the time, those methods involve the time dimension, i.e. the temperature evolution of the sample over the surface. For example the FFT images of the PPT characterize the temperature signal over the time of a given point at the surface of the specimen [3]. Comparing the FFT coefficients between each pixel or from one area to the other over the surface of the sample quickly reveals defective areas that are behaving differently from sound areas. Another similar example is the TSR when used with the 1<sup>st</sup> and 2<sup>nd</sup> derivative or with polynomial coefficients [4, 6]. The Principal component thermography (PCT) also exploits the decomposition of the time-varying temperature signal [4], so does to some extent the DAC contrast [4, 5]. In other words, an image obtained with one of those image processing methods depends on more than one IR image of the IR sequence of images.

This paper explains a how to use the correlation coefficients as an alternative way to characterize the relative difference of the temperature evolution over the time of a sequence of IR images. The correlation coefficient technique is a well-known technique to characterize the linearity between 2 signals. Vavilov defined the correlation technique as calculating the coefficient of correlation between the temperature evolution function of each pixel and the temperature evolution function of a chosen reference point [1]. Although the advantages and disadvantages of the correlation images have not been well explored in the context of PT and modulated thermography. Vavilov noticed a possibly good potential of the method. Very recently Sun et al. [2] applied the correlation method to detect with great success corroded parts of aluminum alloy as used in the aerospace industry.

## 2. DISCUSSION ON CORRELATION COEFFICIENT IMAGES APPLIED ON PT

### 2.1 Principle

In probability theory and statistics the correlation coefficient indicates the strength and direction of a linear relationship between two variables, see for instance the correlation patterns and the corresponding correlation coefficients in Fig. 1. In the infrared context, the correlation coefficient refers to the strength and direction of the linear relationship between a

given temperature evolution reference and all the temperature evolution of the pixels over the specimen under inspection. Like the Fourier transform or the DAC, the correlation coefficient image is mostly sensitive to material changes, being much less sensitive to temperature non-uniformities or initial heat absorption as these are temperature offsets in terms of temperature evolution. The effect of offsets is canceled in correlation computation as offsets do not change the linear relationship between two variables.

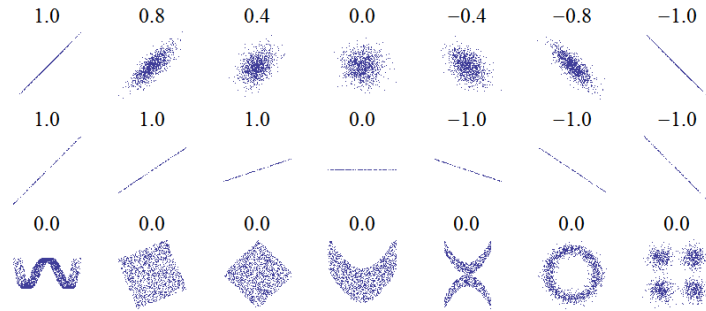

Fig. 1. Correlation coefficients of 2 variables X and Y. Those correlograms are the representation of points of coordinates  $[X(i), Y(i)]$ . This shows that only the linear correlation is measured. On the bottom row there is obviously a strong correlation between X and Y but the correlation coefficient is 0 as these are not linear correlation. Source: Wikipedia, created with Mathematica v6. Source code available online.

## 2.2 Previous results of the correlation coefficient images

Only a couple of studies were found in the literature regarding the correlation coefficient images [1, 2] for IR NDT. Sun et al. did an interesting comparison between the best raw images versus the TSR 1<sup>st</sup> and 2<sup>nd</sup> derivative images, cosine images, correlation images and fitting correlation images on a flat plate slab in aluminum [2]. Both the direct correlation coefficient images and the fitting correlation images gave impressive results on Sun's test sample. To obtain "fitting correlation images", Sun et al. are first smoothing the temperature evolution through a TSR after which the correlation coefficients are calculated. It was concluded – in this case, and this case only - that the fitting correlation images were giving slightly better results than direct correlation coefficient images. Comparing images quality and method from experimental results is always a difficult task as it depends a lot on the sample, the context, the camera, the material and even on people and the way they are setting up the experiment. It is not known if the fitting correlation is always better than the direct correlation but the fitting correlation is an interesting method that worths further investigation.

Sun et al. brought another interesting parameter to consider about the correlation images, namely the time window between which the IR sequence of images starts and ends. They noted a strong influence of the time window, especially with truncated IR sequence on the quality of the correlation coefficient images. Again, it is difficult to evaluate the optimal window size. A too short window size is not representative and would be way too much affected by the high frequency noise. On the other hand, a too long time window may cancel out the difference of temperature evolution between defective areas and sound areas as both tend to 0°C. One can make the reasonable assumption that a good window time duration should be long enough to include a relevant part of the temperature evolution of each area of the sample to test but should not be longer than the time at which the maximum contrast of the deepest defect would occur.

## 3. PRACTICAL IMPLEMENTATION

Correlations involve 2 variables: the first one is the reference; the second one is the variable one wishes to compare against the reference. Both Vavilov [1] and Sun [2] suggested using the temperature evolution of a pixel referred to as a reference point on the image. In practice almost any point that is not a dead pixel can be used. Choosing one pixel or another will change the correlation coefficient because of variations in non-uniform heating, emissivity variations, etc.. Nevertheless what matters in terms of qualitative analysis, is the difference of correlation between each pixel only. Selecting a pixel from a sound area as the reference or selecting a pixel from a defective area is more or less equivalent

to change the colorpalette used to represent the correlation image coefficients. This means that even using a straight and decreasing slope as a reference can work. A cleaner way to proceed is to compute the reference from a semi-infinite body by taking the initial temperature of any point of the first frame of the IR sequence of images. More details about computing such a reference can be found in DAC contrast computation [5]. An even simpler way is to compute the average of the temperature evolution of all the pixels. This avoids having to manually select a reference. Another minor issue is that the dynamic range of the correlation coefficient is rather big. Thus, non-defective areas may show a correlation coefficient difference of about  $1e10^{-5}$ , small defects may show a correlation difference of  $1e10^{-4}$  whereas bigger defects may show a correlation difference of about  $1e10^{-1}$ . Logarithmic colorpalettes are thus more appropriate than linear colorpalettes, as linear colorpalettes will show sound areas and small defective area with the same color. An alternative to using logarithmic colorpalettes is to compute the  $n^{\text{th}}$  root of the correlation coefficients such a way smaller defects get bigger correlation coefficients. An implementation of the correlation image computing is available on ThermoFitPro [7] and IR View [8]. The following examples are computed with IR View [8].

#### 4. EXPERIMENTAL RESULTS ON VARIOUS SAMPLES

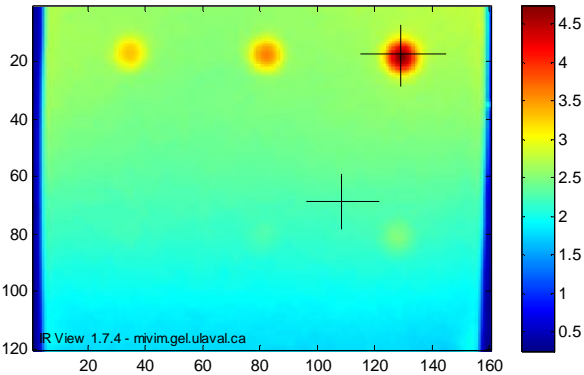

Fig. 2. This is a test sample in Plexiglas pulsed thermography that has a total of 6 defects (flat bottom holes) with increasing deepness. Two points are shown on this thermogram. The first one belongs to defective area. The second one is located over a sound area. The correlograms of those 2 points taking an average of the whole sequence as a reference are given on the next figure. The scale is in degrees Celsius.

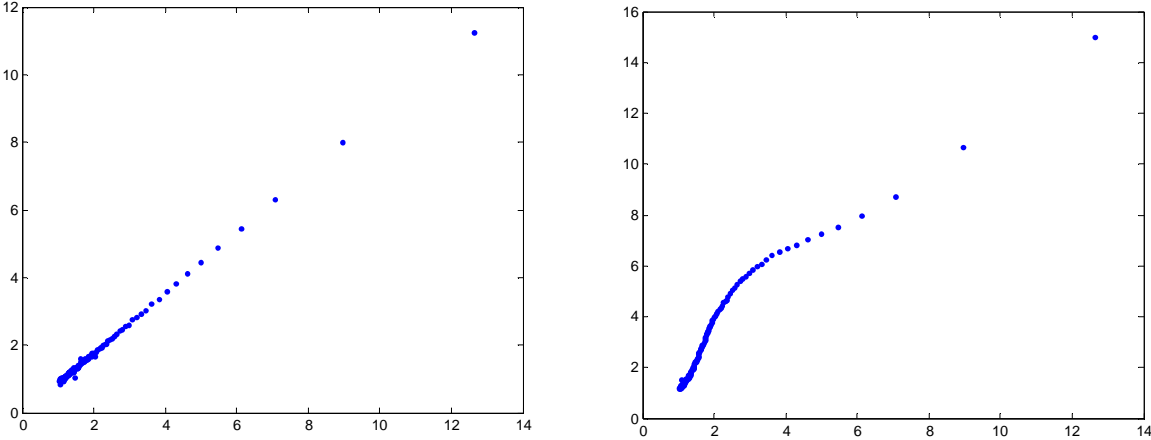

Fig. 3. Left: Correlograms of the temperature evolutions of the previous figure, of the sound area (left) and the defective area (right). The defective area shows a lower correlation coefficient, as it is less linear. Correlograms can't be seen a continuous line but as point clouds or sparse points only. The scales on X and Y is in degrees Celsius.

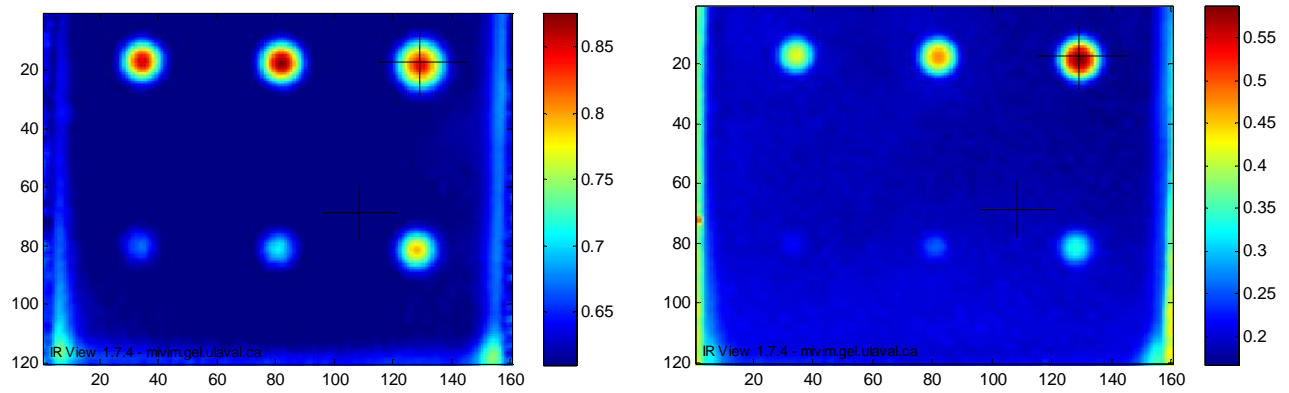

Fig. 4. Left: PPT phase (or amplitude) image showing the best overall contrast for the 6 defects. Right: Correlation image of the same sample. The colorbar value shows the 5<sup>th</sup> root of 1-c, where c is the computed correlation coefficient. The correlation image is not as good as the best PPT in this case but still shows good sound area uniformity.

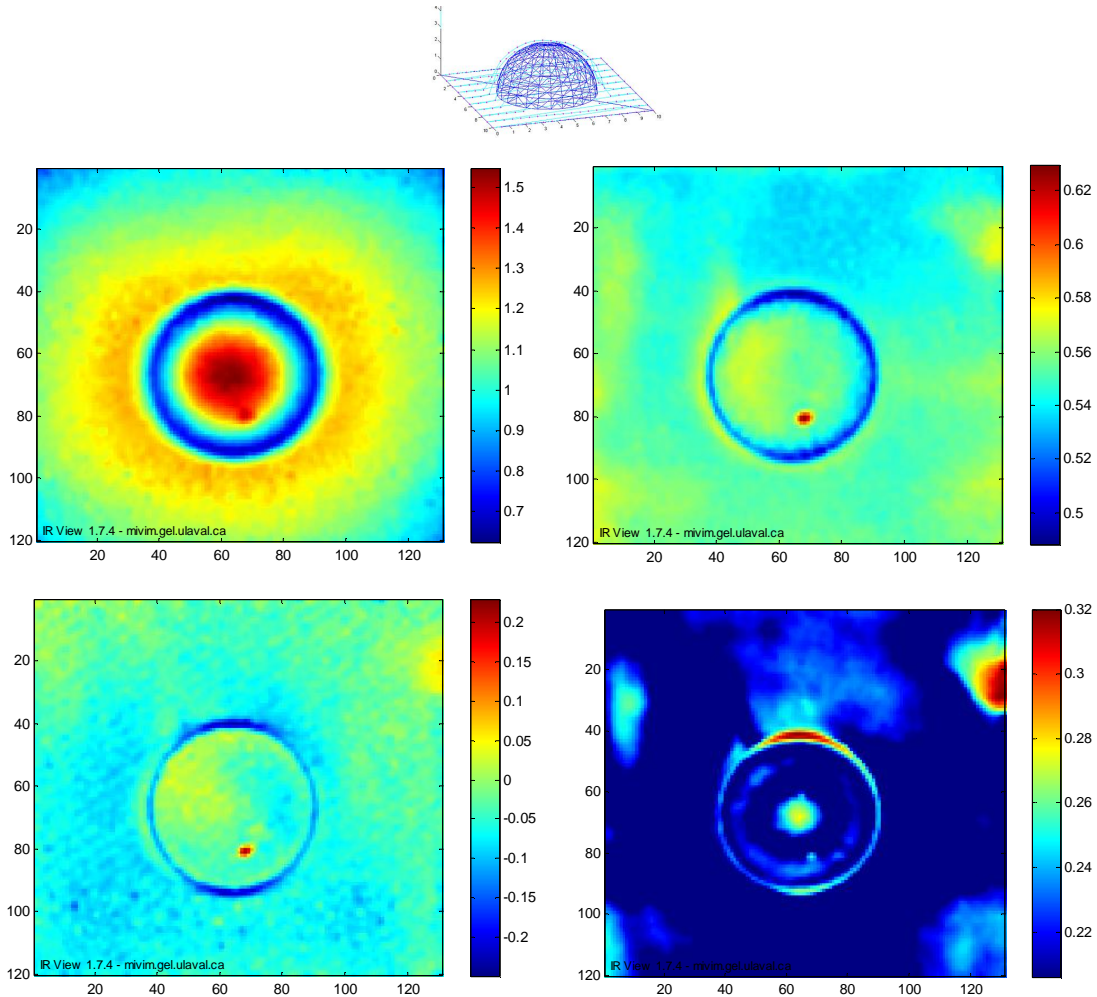

Fig. 5. This is a half sphere in Plexiglas glued on a flat slab plate. The half sphere contains a small hidden defect in its lower part. Top left: best raw temperature image. Top right: best FFT image. Bottom left: best DAC contrast image. Bottom right: correlation image with adjusted colorpalette. (3D drawing by *Anders Wallin*)

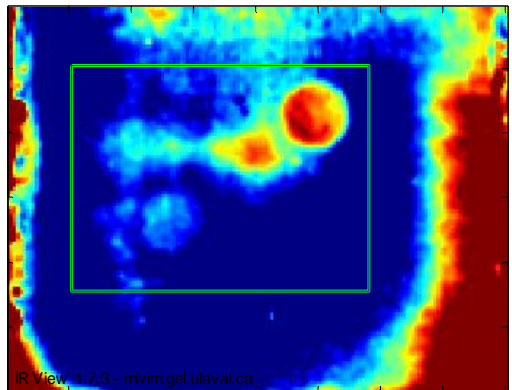
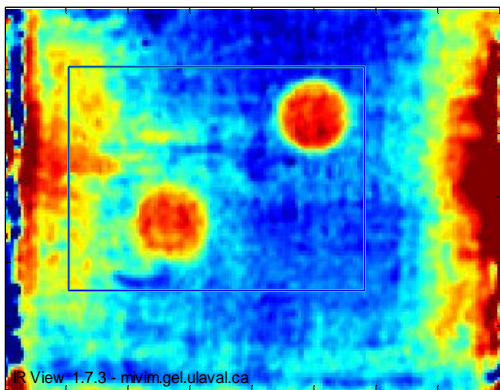
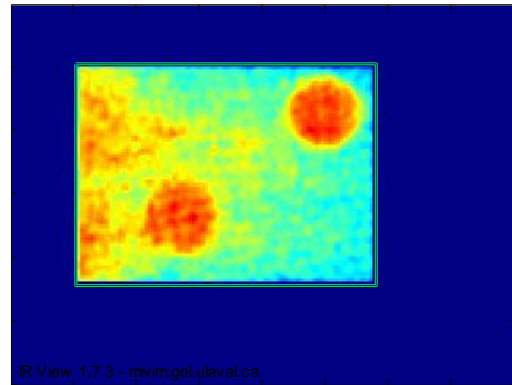
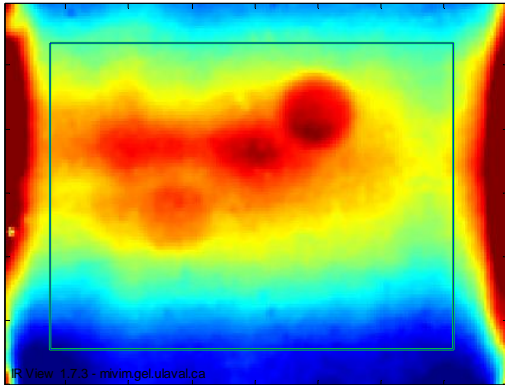
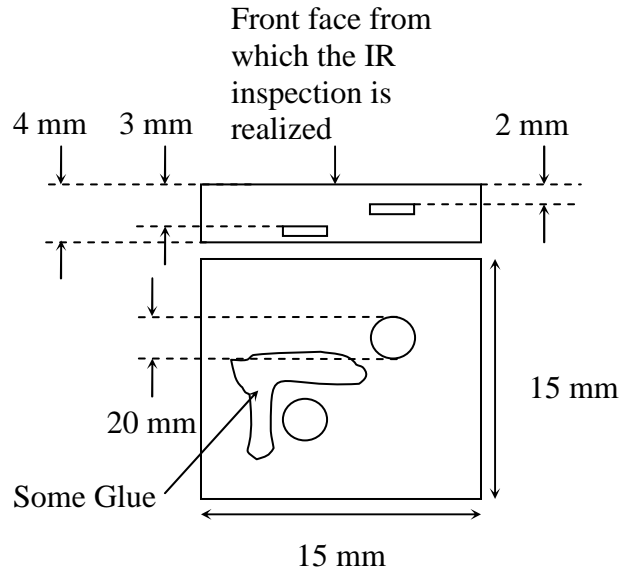

Fig. 6. The drawing shows a CRFP plate slab sample with 3 known defects (1 glued area and 2 circular fluorocarbon resin implants). Top Left: best raw temperature image. Top right: Best PPT phase image. Bottom Left: Best DAC contrast image. Bottom right: correlation image. All the images have their colorpalette adjusted to a boxed region of interest. Notice the correlation image is the best to detect the shape of the glue between the 2 defects.

## 5. CONCLUSION

The correlation image processing was and still is a relatively unexplored way of accentuating small subsurface defects in pulsed thermography. It may also work quite well in lock-in thermography. In any case it has proven to be efficient in most of standard cases of PT. A major interest of the correlation image is its simplicity of application since no specific parameters are required to compute the correlation coefficients. This is especially true if the temperature evolution of reference is obtained by averaging the temperature evolution of each pixel. Correlation coefficient images give different results versus the other time or temperature evolution aware methods such as the PPT, TSR, DAC. This makes the correlation coefficient method a complementary method when it is needed to quickly evaluate materials under PT inspection.

## ACKNOWLEDGEMENTS

The authors want to thank Mariacristina Pilla for the perfect IR acquisitions of the samples and to the National Research Council of Canada for the financial support.

## REFERENCES

- <sup>1</sup> Vladimir Vavilov, "Evaluating the efficiency of data processing algorithms in transient thermal NDT", Proc. SPIE 5405, 336 (2004)
- <sup>2</sup> Busheng Sun and Qishuang Ma, Hongfeng Zhao, "Fitting-correlation Analysis of Pulsed Thermographic Sequence Data", Proceedings of the 2007 IEEE, International Conference on Mechatronics and Automation, August 5 - 8, 2007, Harbin, China.
- <sup>3</sup> X. Maldague and S. Marinetti, "Pulse phase infrared thermography", *J. Appl. Phys.*, 1996, Vol.79, pp. 2694-2698.
- <sup>4</sup> C. Ibarra-Castanedo, D. González, M. Klein, M. Pilla, S. Vallerand and X. Maldague, "Infrared image processing and data analysis", *Infrared Physics & Technology* Vol. 46, Issues 1-2, December 2004, pp.75-83.
- <sup>5</sup> M. Pilla, M. Klein, X. Maldague, A. Salerno, "New Absolute Contrast for pulsed thermography," Archives of QIRT 2002, Croatia
- <sup>6</sup> R.E. Martin, A.L. Gyekenyesi, S.M. Shepard, Interpreting the results of pulsed thermography data, *Mater. Eval.* 61 (5) (2003) 611-616.
- <sup>7</sup> Software *ThermoFitPro*, from Innovation Inc. [http://www.innovation.tomsk.ru/ind\\_en.html](http://www.innovation.tomsk.ru/ind_en.html)
- <sup>8</sup> Matthieu Klein, Clemente Ibarra-Castanedo, Abdelhakim Bendada, Xavier Maldague, "A straightforward graphical user interface for basic and advanced signal processing of thermographic infrared sequences," SPIE Proc. Thermosense 30th (SPIE: Society of Photo-Optical Instrumentation Engineers), Orlando, 2008